

# Installation Instructions: Wattage Switchable Highbay: 70340

Read these instructions before installation and retain for future reference

This equipment should be installed by a competent electrician



## Important Information

We recommend that luminaires are installed by a qualified electrician ensuring the installation complies with current IEE wiring regulations BS7671:2018 & local building control.

- BELL will not accept responsibility for any claims arising from a poor installation.
- Do not cover with any insulation.



This product may contain substances that can be hazardous to the environment if not disposed of properly. Electrical and electronic equipment should never be disposed of with general household waste but must be separated for its correct treatment and recovery.

Where possible recycle your packaging.



## Physical Dimensions (Unit: mm/inch)



Power	Size(L1)	Size(L2)
100W/150W/200W Selectable	954(37.56")	981(38.62")

Product Specifications	100W/150W/200W Selectable
Input Voltage	220-240VAC (Subject to the input voltage on nameplate)
Power Frequency	50/60Hz
Outlook Dimensions	954x126x109mm(37.56"x4.96"x4.29")
Net Weight(±6%)	4.87kg(10.74Lbs)
Working Temperature	-30°C +40°C(-22°F to +104°F)

\* Please subject to actual product for accurate weight.

## Ceiling Mount

1. ✖

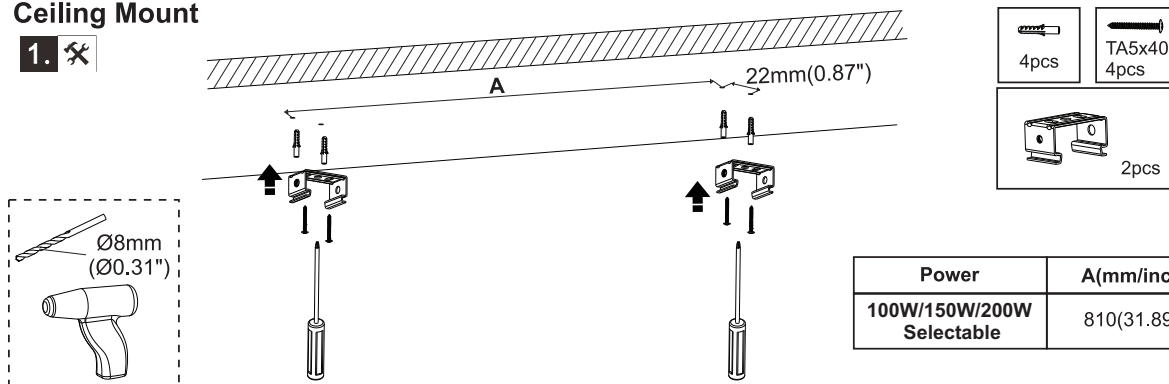

Power	A(mm/inch)
100W/150W/200W Selectable	810(31.89")

2. ✂

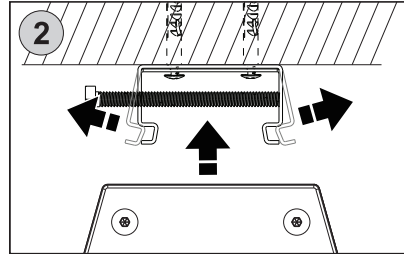
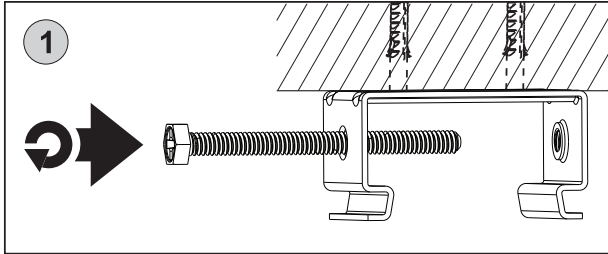
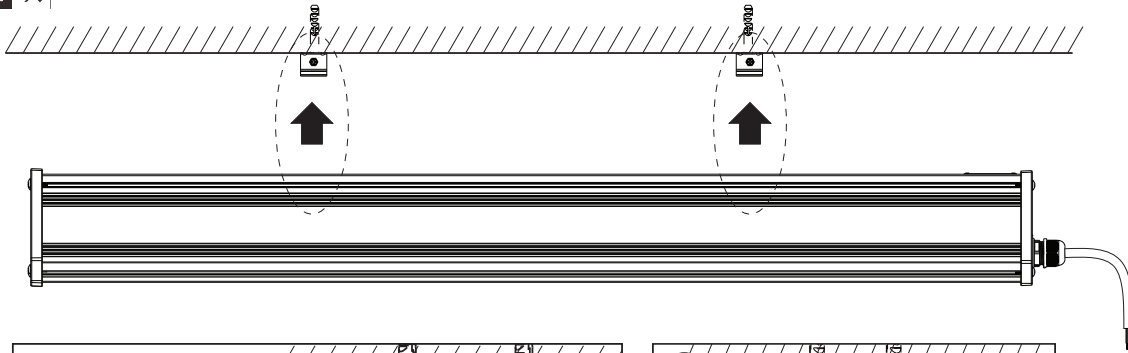

3. ✂

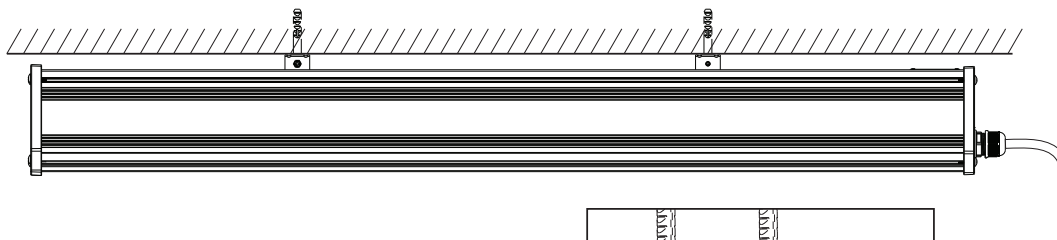

M4x50  
2PCS  
1.2 N.m

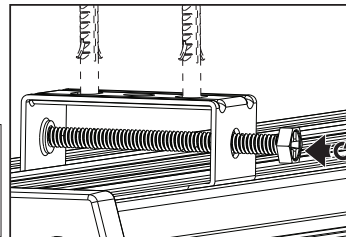

### Suspension Mount

1. ✂

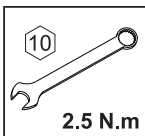
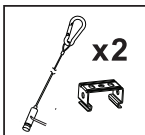
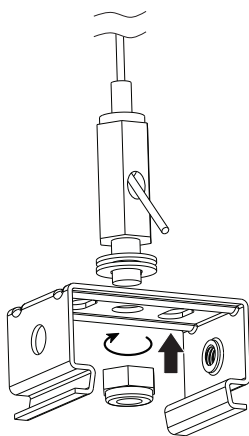

2. ✂

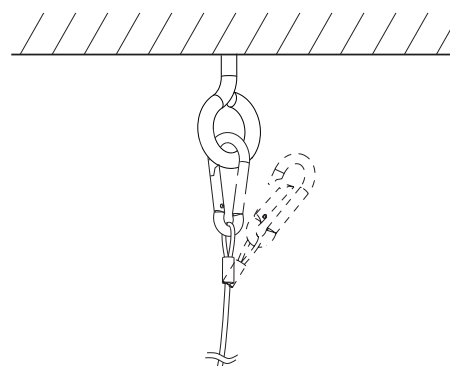

3. ✖

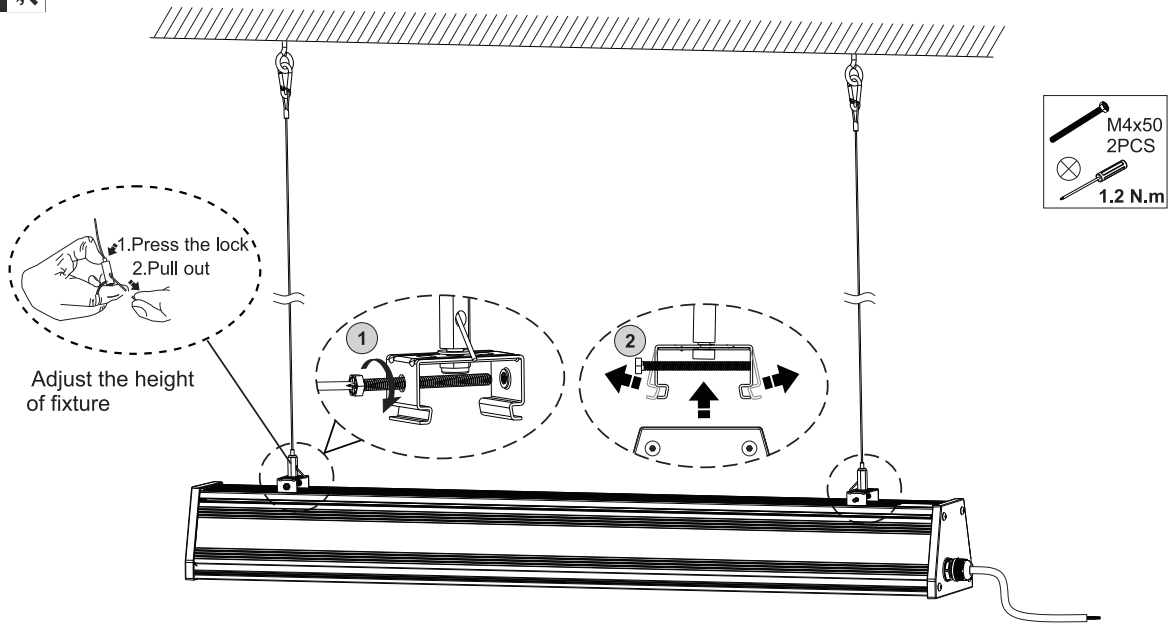

## Wattage Selectable Function

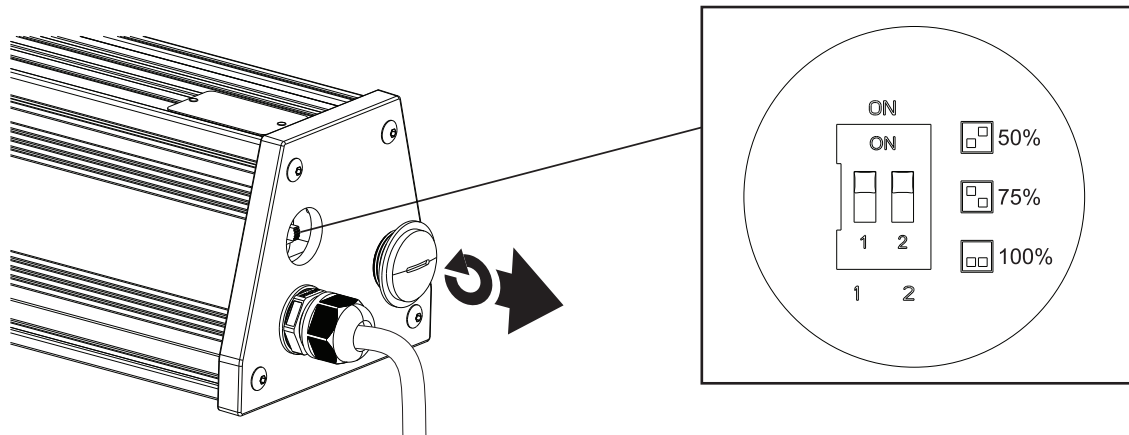

## Sensor Installation (Optional)

1. ✖

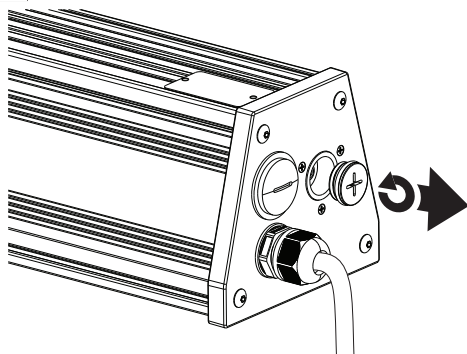

2. ✖

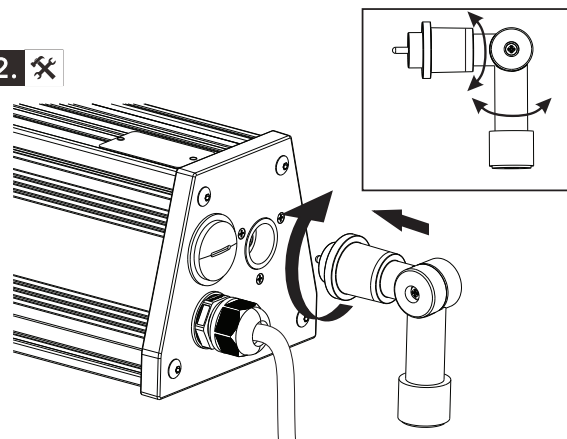

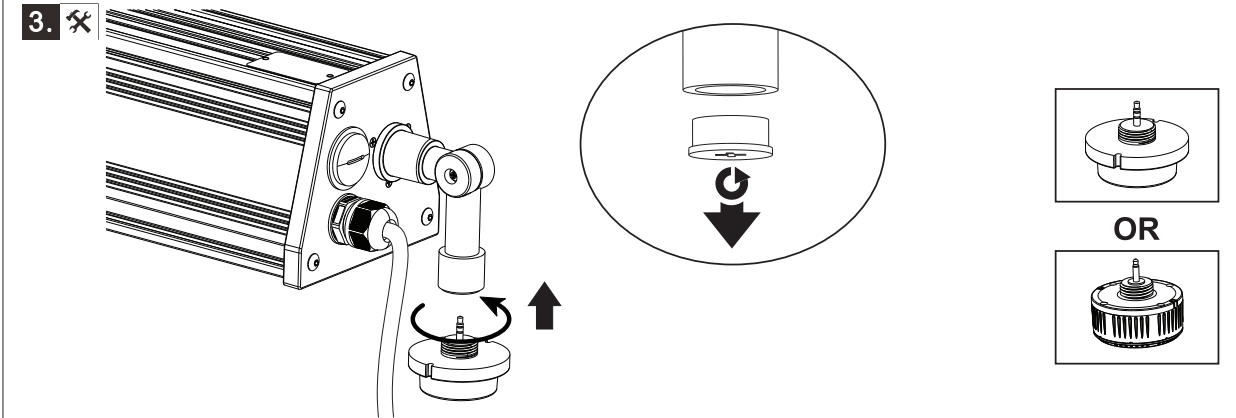

**AC cords**

<b>L</b>	brown		black
<b>N</b>	blue		white
	yellow/green		green

**DIM cords**

**Note: color for dim cords subject to the cable label on luminaire**

